



# WORKPACKAGE 5: EDUCATION AND ECONOMIC PROMOTION

Workpackage progress report,  
Discussion on future plans

2012-02 Veliky Novgorod



Co<sub>2</sub>olBricks





## WP5 international meetings in 2011

- Meeting in Hamburg – setting of initial tasks, discussing the educational goals and possibilities;
- Meeting in Visby – discussing the baseline study “Educational Situation in BSR” topics, defining accessible information for all WP5 PP;
- Meeting in Helsinki – discussing additional topics of baseline study, preparing questionnaire for it, discussing categories of learning packages, learning contents to be developed;
- Meeting in Malmo – discussion of activities in WP5 during next project periods (3<sup>rd</sup> and 4<sup>th</sup> ), preparing timetable and information about the project activities for the public.



## Aim of WP5

- To upgrade the knowledge and education of architects, engineers, craftsmen, etc.
- To harmonise the teaching programs with labour market
- To strenghten the market possibilities of innovative SMEs in Baltic Sea Region



Co<sub>2</sub>olBricks



## Main tasks of WP5:

- To prepare new curricula (teaching programmes)
- To prepare new training and learning modules
- To prepare new lecture materials
- To spread the achieved specialised knowledge



Co<sub>2</sub>olBricks



## Six consecutive steps:

WP5.1 Baseline study

WP5.2 Advanced Knowledge of General Public and Stakeholders

WP5.3 Additional Qualification for Energy Experts and Architects

WP5.4 New Training Program and Qualification Tools for Specialized Craftsmen

WP5.5 Cooperation of Craftsmen Teaching Programs in the Baltic Sea Region

WP5.6 Strengthening the Market Opportunities of Innovative SMEs (Small and Medium Enterprises)



Co<sub>2</sub>olBricks



# WP5 Education and Economic Promotion

## Baseline study

### “Educational Situation and Labor Market Conditions” draft

Collected data for all countries represented by PP in Co2olBricks project:

- Labor market general descriptions
- Types of educational institutions, levels of study;
- Number of educational institutions;
- Stages of studies;
- Teacher education;
- Information about non-traditional studies like distance training, lifelong education, higher educational training in industry;
- Schemes of educational system;
- Level of education of different target groups of the project;
- Missing parts of education;
- Contact data of authorities responsible for education.



Co<sub>2</sub>olBricks



## Estonia

Area	45 227 km <sup>2</sup>
Population	1.34 million
Population density	29/km <sup>2</sup>
GDP total	€ 15.233 billion
GDP per capita	€ 11 446



### Represented by:

- PP10 Information Center for Sustainable Renovation NGO (SRIK)
- PP11 Kohtla-Järve Town Government
- PP12 The Centre for Development Programs, EMI-ECO

## STRUCTURE OF EDUCATION SYSTEM

### School education:

General education is divided into two parts: basic education (9 years: age 7 to 16) which is compulsory for all children in Estonia and secondary general education. Since 1993, the Basic School Leaving Certificate, obtained at the end of basic education, provides a student with the right to continue at the next level which offers two streams (in three further years): 1) Secondary general school/gymnasium education and 2) vocational education.

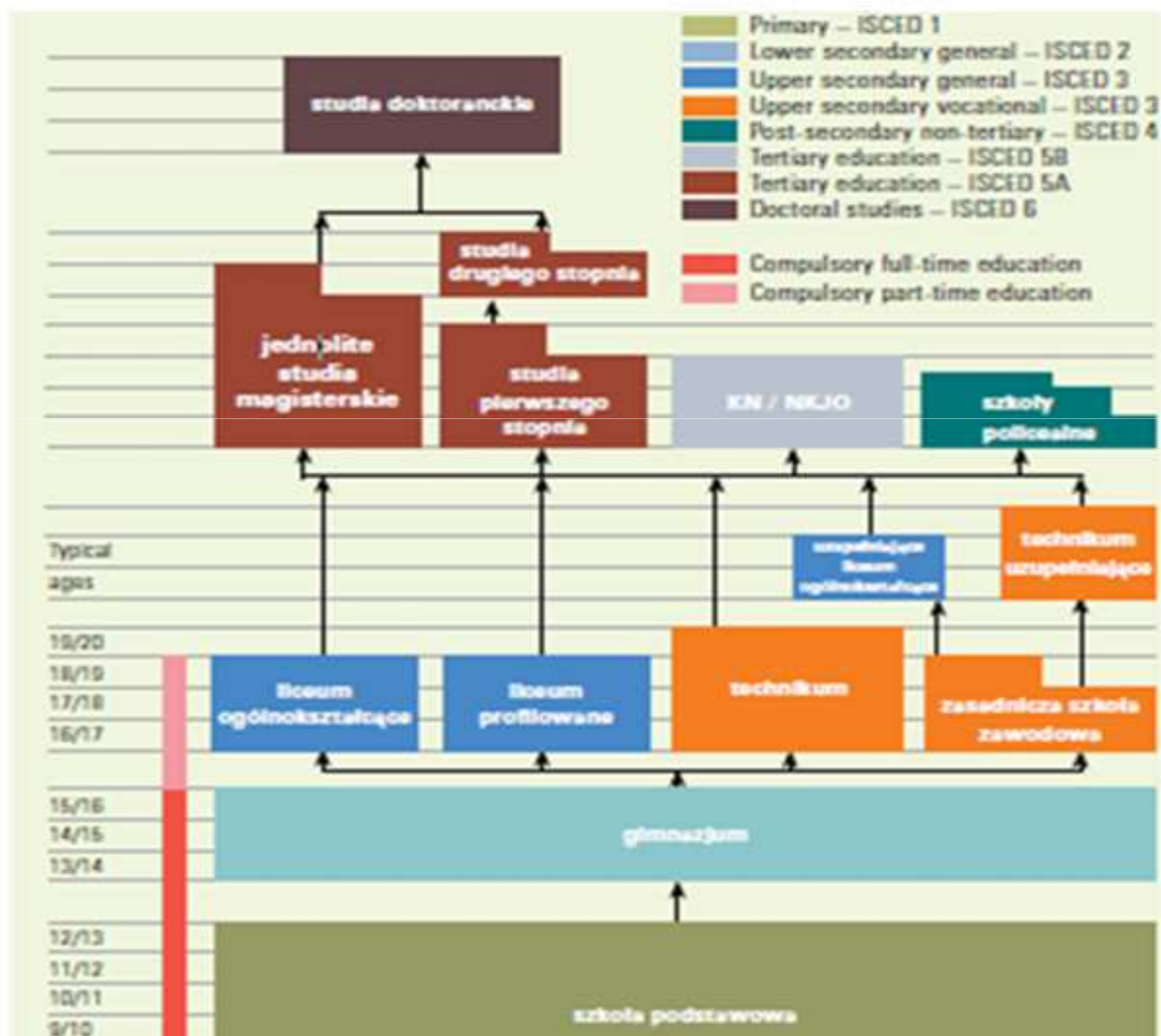



---

**Finnish National Board of Education (Opetushallitus)** - : Development, evaluation and information services related to education; Finnish ENIC-NARIC; competent authority for the professional recognition of foreign higher education qualifications.

P.O.Box.380 (Hakaniemenkatu 2), 00531 Helsinki, Finland Tel: +358(9) 774775, <http://www.oph.fi/english>

**Finnish Higher Education Evaluation Council -FINHEEC (Korkeakoulujen arviointineuvosto)** - : Independent expert body assisting universities, polytechnics and the Ministry of Education in matters relating to evaluation

P.O. Box.133, FI-00171 Helsinki, Finland Tel: +358(9) 16076913, <http://www.finheec.fi>

**Centre for International Mobility - CIMO (Kansainvälisen henkilövaihdon keskus)** - : Services and expertise in cross-cultural communication; promotion and administration of scholarship and exchange programmes; implementation of EU education, training, culture and youth programmes at national level

P.O.Box.343 (Hakaniemenkatu 2), FIN-00531 Helsinki, Finland Tel: +358(9) 77477033, <http://www.cimo.fi>

**Finnish Council of University Rectors (Suomen yliopistojen rehtorien neuvosto)** - Development of the university sector of higher education; a common forum for universities

P.O.Box.3, University of Helsinki, 00014 Helsinki, Finland Tel: +358(9) 19122335, <http://www.ctors-council.helsinki.fi/>

**The Rectors' Conference of Finnish Polytechnics (Ammattikorkeakoulujen Rehtorineuvosto - ARENE)**

Rikhardinkatu 4 B 22, FIN-00130 Helsinki, Finland Tel: +358(9) 6129920, <http://www.arena.fi>

**Centre for International Mobility (CIMO)** - Principal national bodies responsible for dealing with international cooperation and exchanges in higher education:

P.O.Box.343 (Hakaniemenkatu 2), FIN-00531 Helsinki, Finland Tel: +358(9) 77477033, <http://www.cimo.fi>

## Conclusions: 1. Basic information

- The educational systems of all participating countries are quite similar containing mostly three levels of education, of which project is interested mostly in higher education for craftsmen, university education,
- There are also alternative education in all the countries where additional education is given (qualification courses for professionals, vocational training);
- There is a common problem with calculating energy efficiency in comparable way;
- There is usually a misunderstanding between architects and conservators on the parts of building to be preserved;
- We need to develop lecture materials to give the information the different target groups and raise their level of understanding.

## Conclusions: 2. Level of education

- University teachers' knowledge is mostly ranked at a satisfactory level.
- Architects specialize strongly in either new construction or refurbishing. Those who work with old buildings have usually very good understanding of cultural value, but their knowledge must be maintained and extended to new materials and repair methods.
- Parties involved in doing energy usage audits generally have good knowledge of energy usage and its calculation. Knowledge of building physics and structural damage should be increased.
- The big concern is the knowledge and education of general public, house owners and stakeholders – they usually lack the necessary knowledge;



## Training materials

- The training materials will consist of 18 different themes divided into 4 lecture packages
- There will be same themes for different levels of education. The most detailed lecture materials will consist of ~15 text pages, ~10 pictures and tables, additional materials like illustrations, photographs etc.
- The material is being prepared mainly by VGTU, other partners will add their contributions according to their specialization (as example AZB Hamburg will contribute greatly preparing materials for craftsmen target group)
- Project partners are approving the prepared initial materials and making adaptations for their purposes.
- All the materials will be prepared in English language and distributed between project partners and other educational institutions.

# Educational target groups

- General public,
- stakeholders,
- building companies,
- officials (like building conservation officers, municipality representatives responsible for culture heritage and national refurbishment programs),
- architects,
- building conservators,
- building supervising staff,
- energy auditors,
- teachers in universities,
- teachers in polytechnics, vocational training centers etc.,
- students,
- working craftsmen,
- apprentices.



# Training materials

- **1. Cultural heritage and historic constructions**
- Introduction into cultural heritage buildings
- **The history of brick masonry construction in BSR**
- Preserving cultural heritage in BSR: problems and lessons learned
- **Historic masonry construction**
- **Damage pattern of historic masonry construction**



## Training materials

- **2. Energy efficient refurbishment measures and technical services (heating, ventilation, indoor climate)**
- **Thermal conductivity and moisture regimen**
- Computer software for calculation of thermal conductivity and moisture regimen
- **Refurbishment measures of historic masonry construction**
- Lifecycle of the buildings from the energy consumption perspective
- Innovative heating systems and usage of it in historic buildings
- Energetic refurbishment of historic buildings



## Training materials

### 3. Quality Management and work planning

- Management stages of construction projects, planning of the refurbishment process
- Public procurement in construction market
- Evaluation of rationality of investment

### 4. Market opportunities

- Market opportunities in BSR
- Reliable building materials and products for refurbishment of historic buildings
- Construction market in BSR
- Local raw material usage in BSR countries
-



# Drėgmės šaltiniai. Atmosferos drėgmė

## Kritulių infiltracija ir pratekėjimai



# Drėgmės šaltiniai. Garų drėgmė

## Garų kondensacija paviršiuje

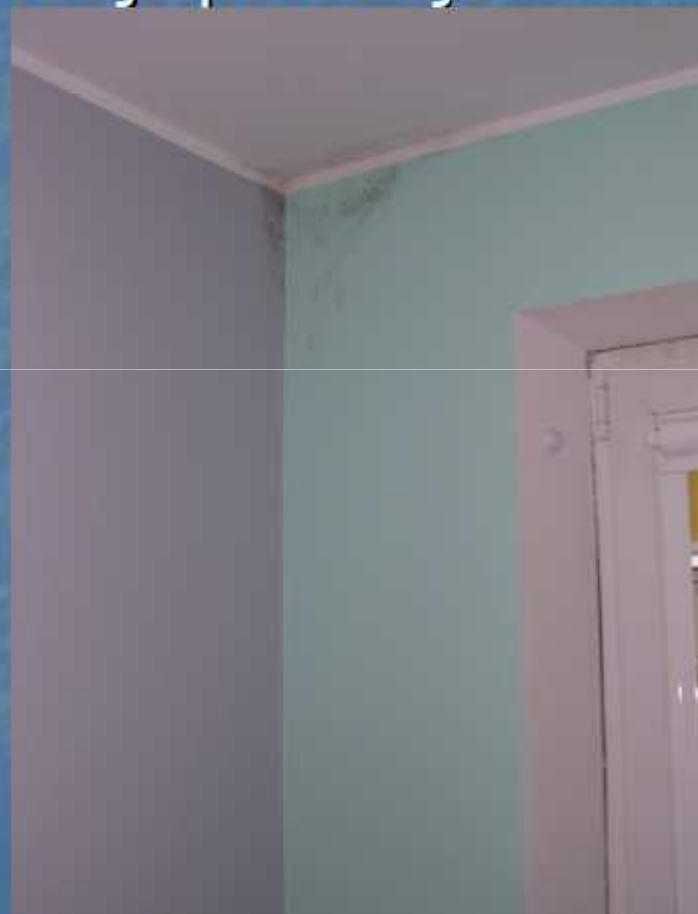



# Drėgmės šaltiniai. Garų drėgmė

## Garų kondensacija atitvaros viduje



Grunto drēgmē

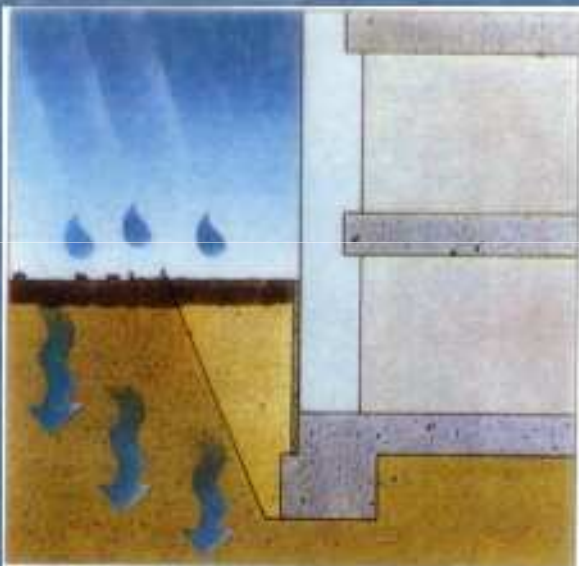

Nespūdinis gruntinis vanduo

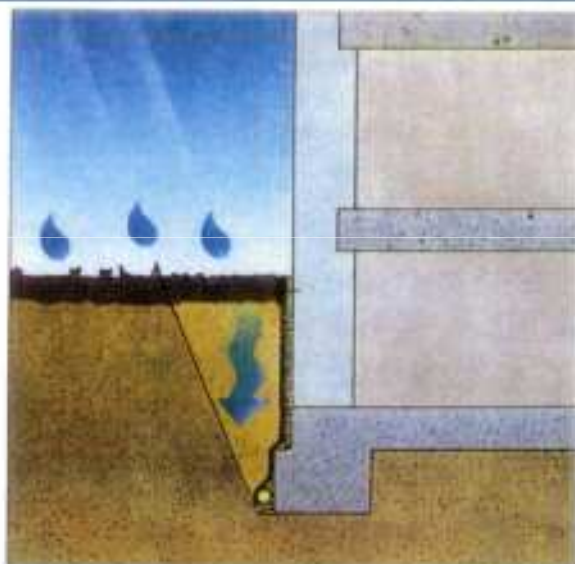

Spūdinis gruntinis vanduo

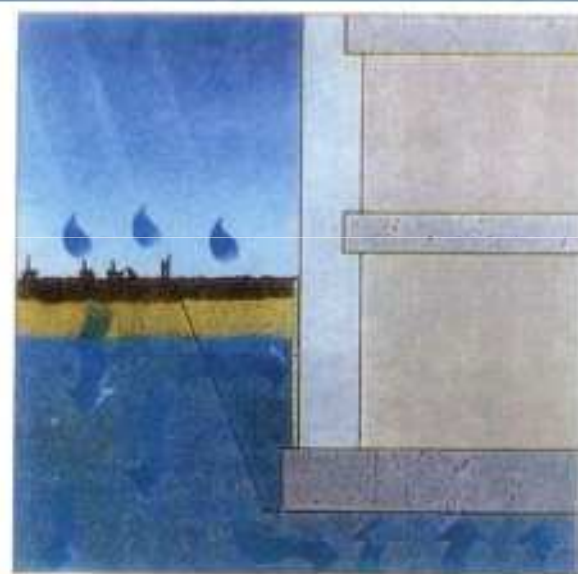

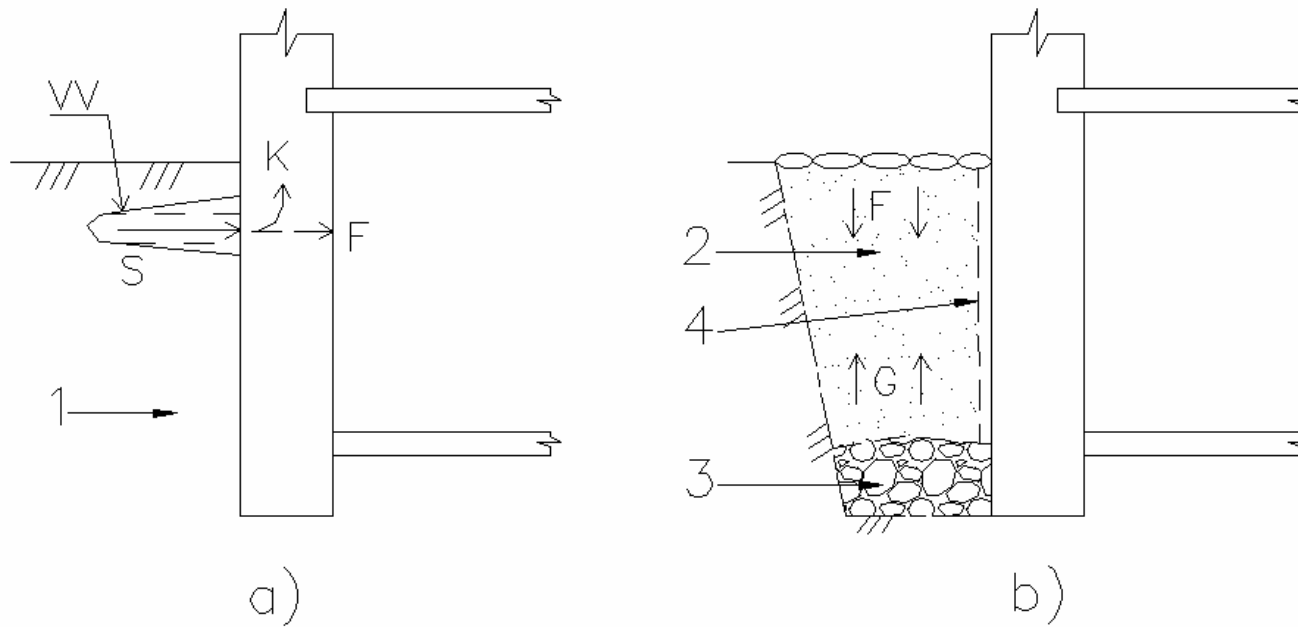
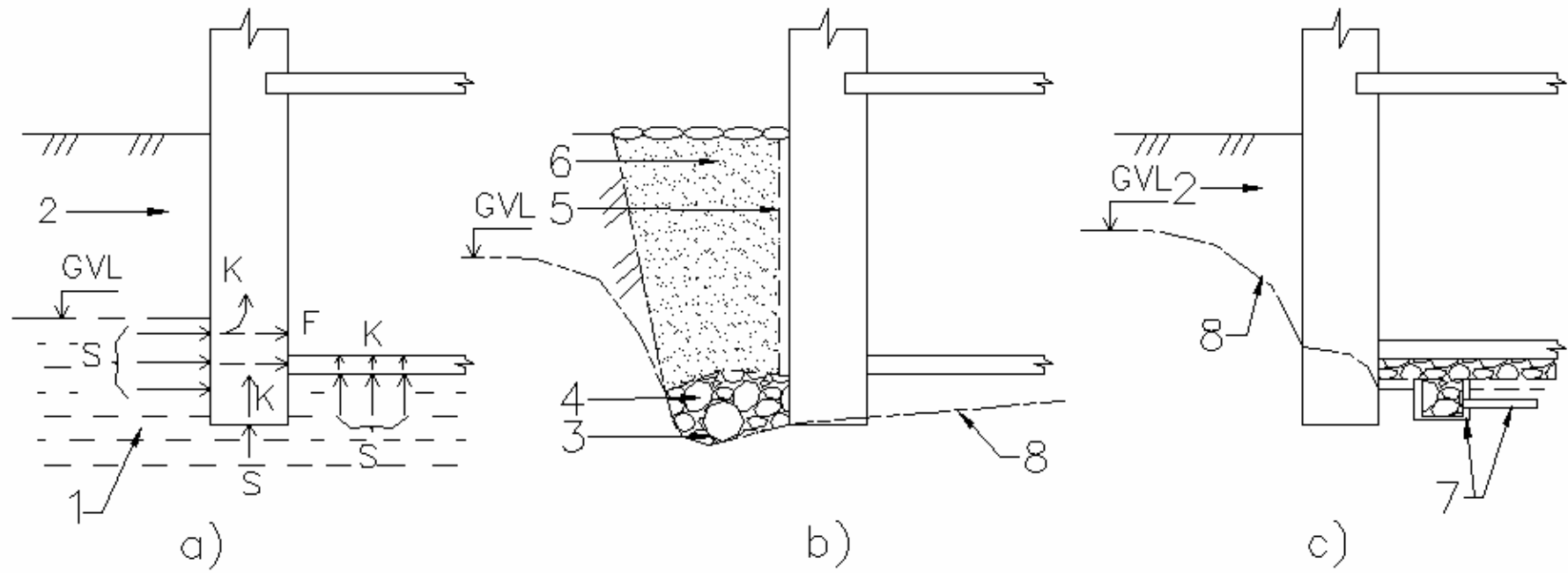



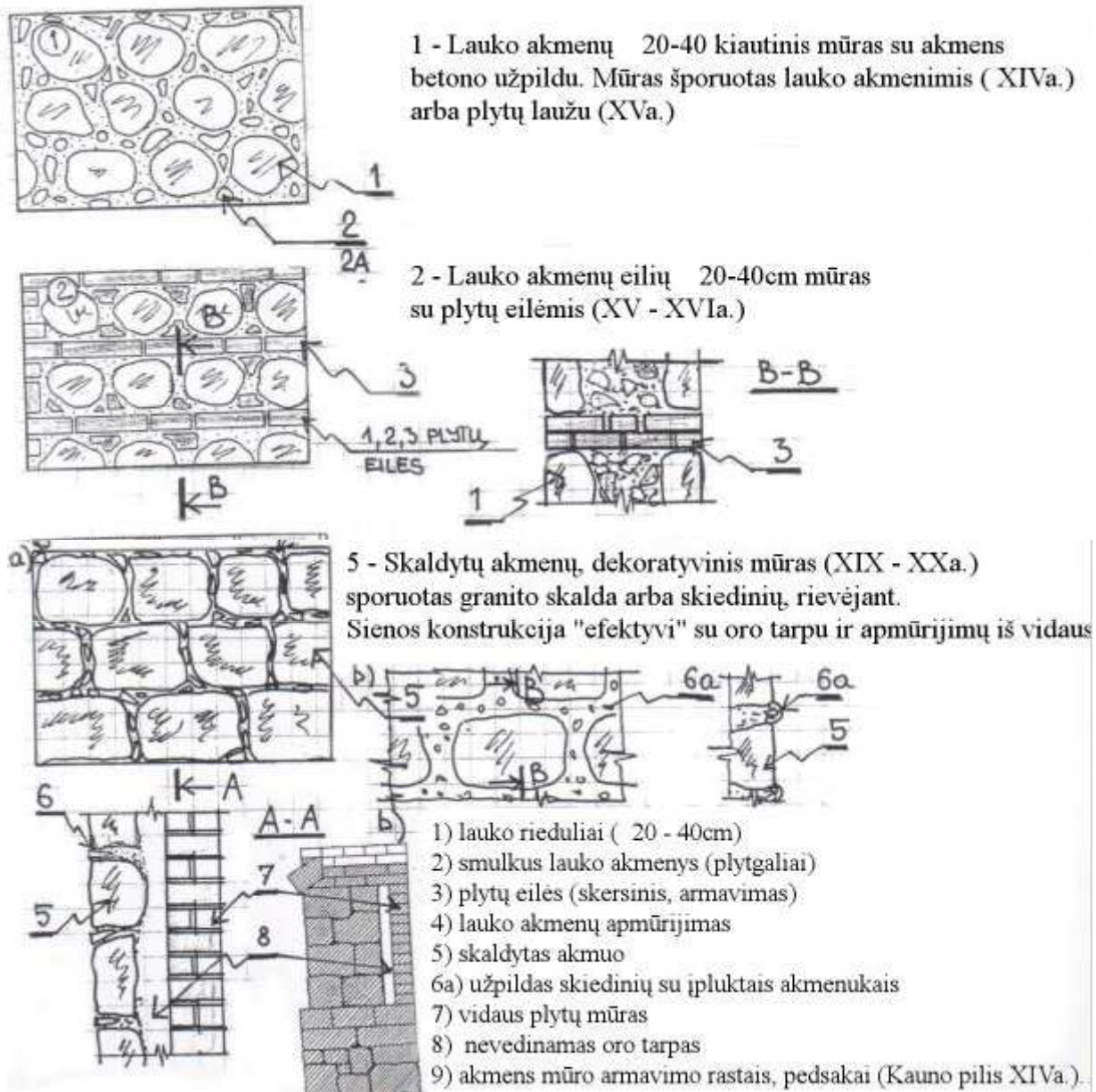

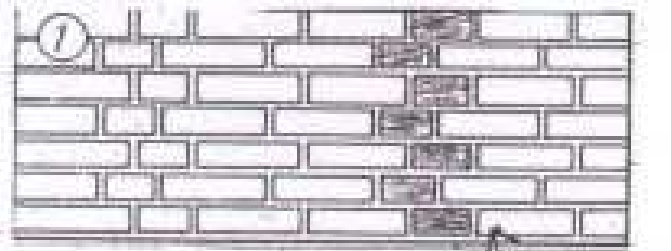

KIAUTAS

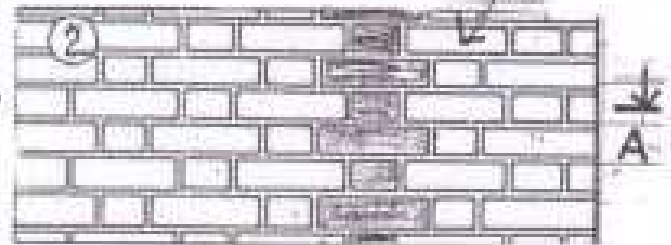

A-A

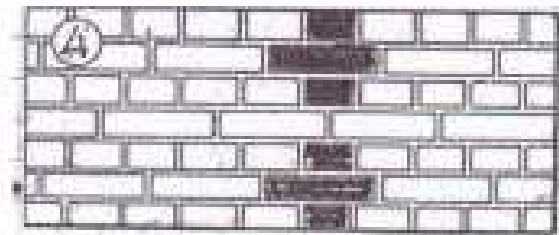
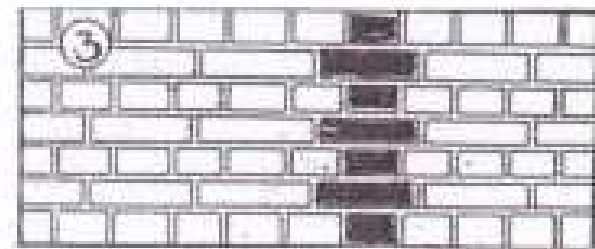

K.G

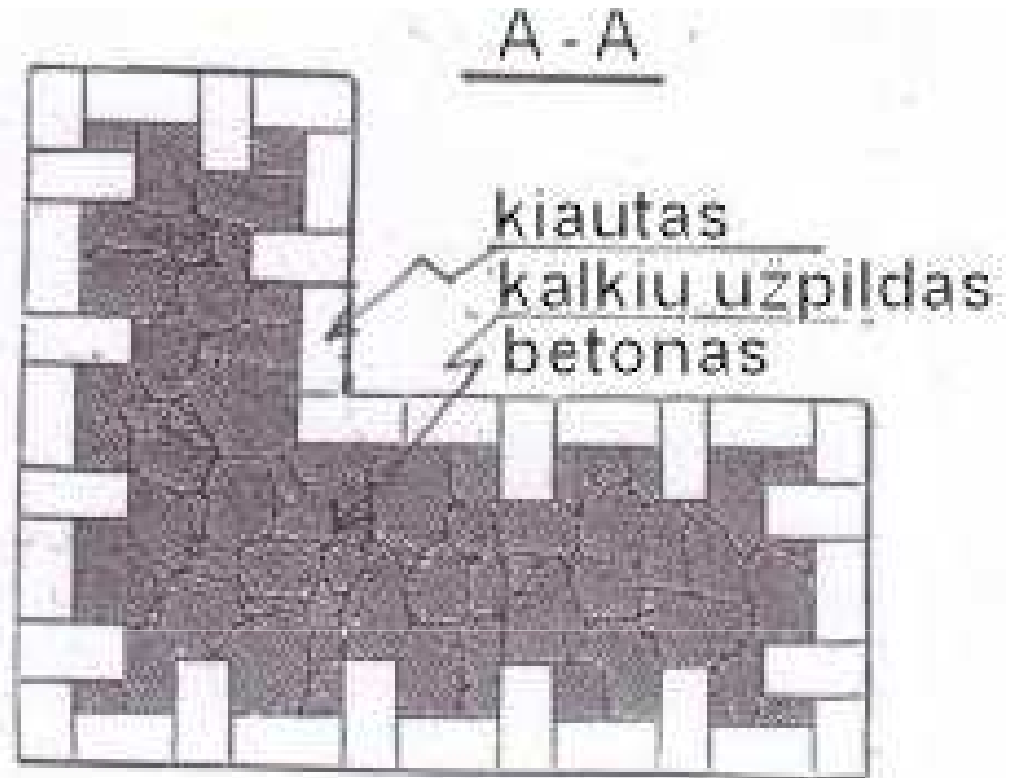

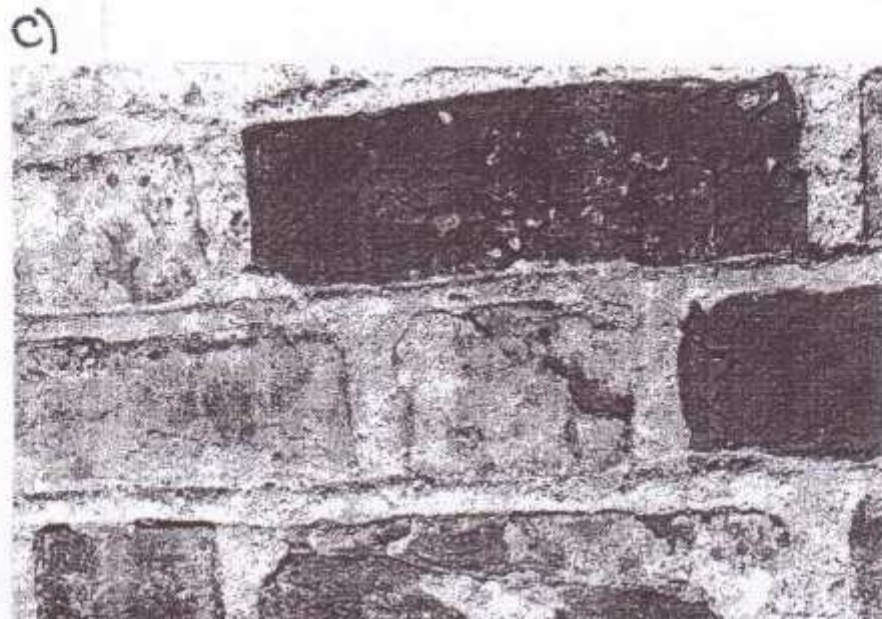
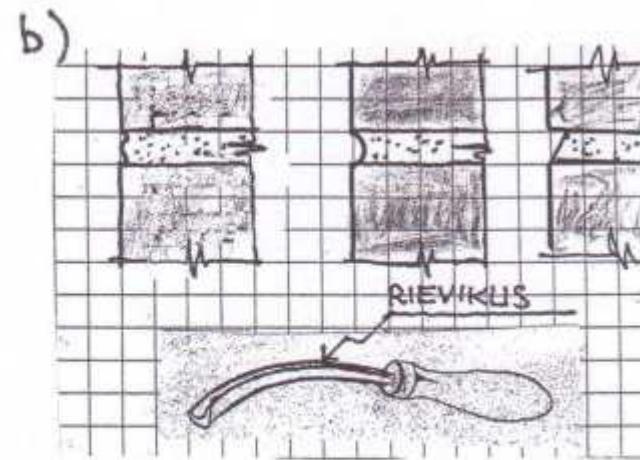
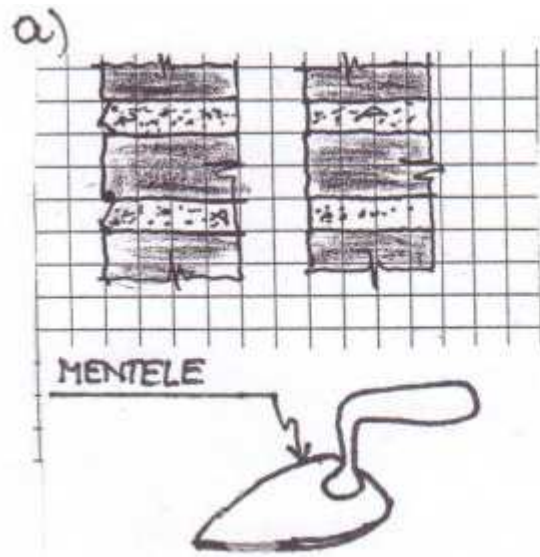



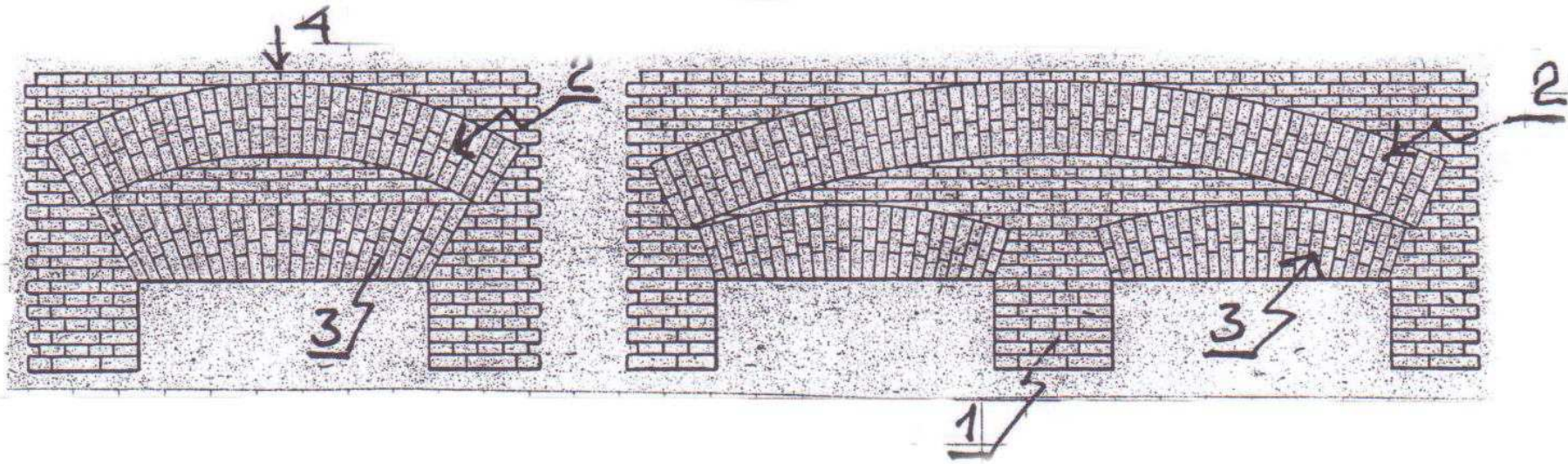
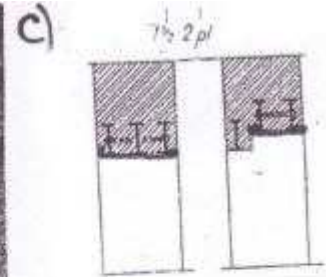
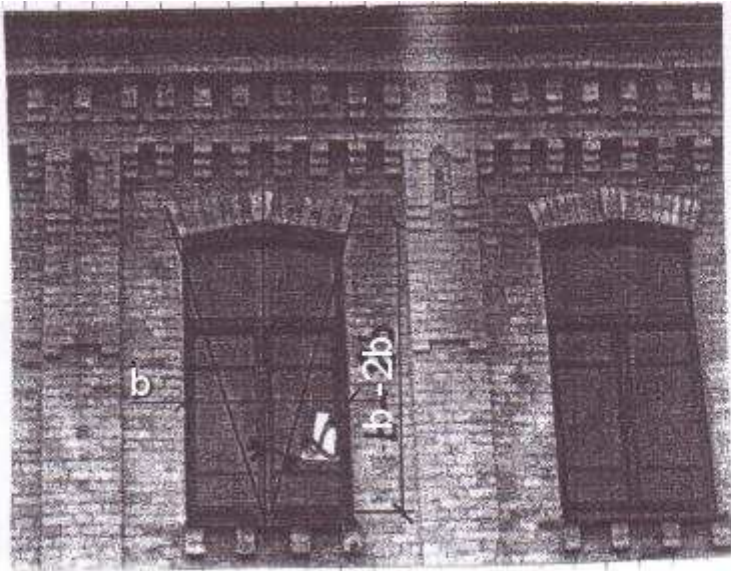
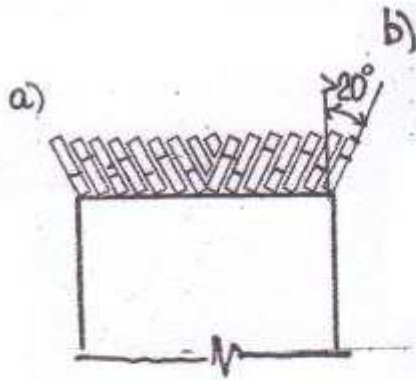

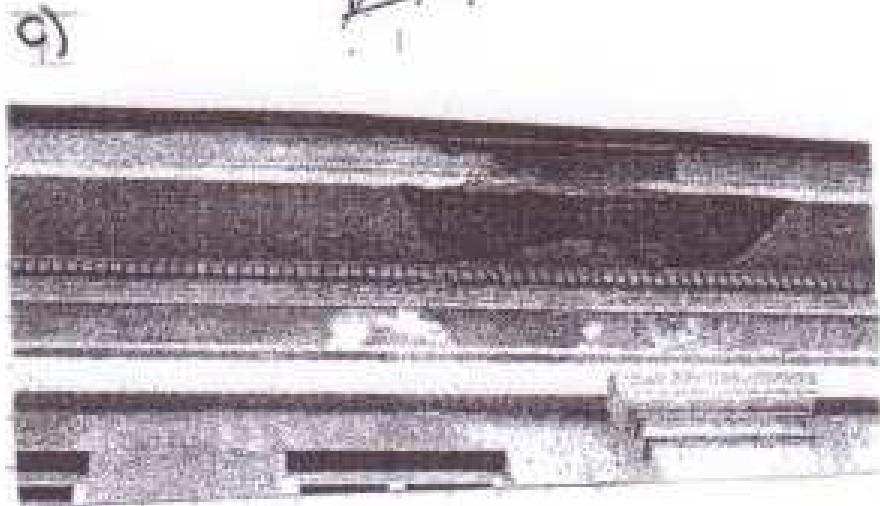
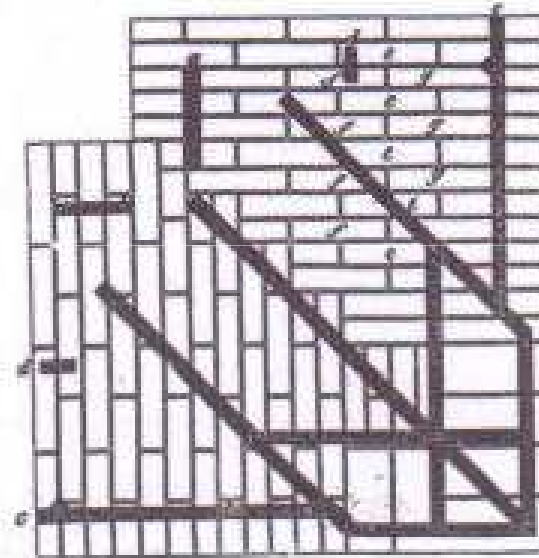
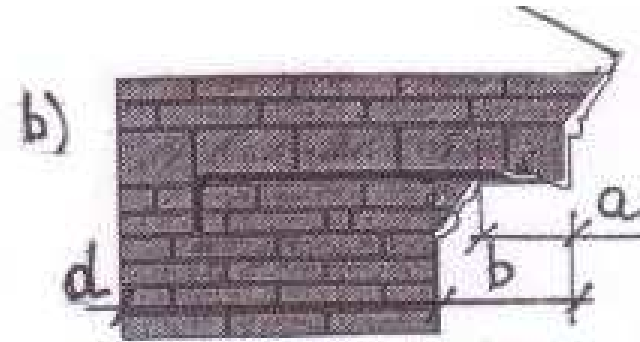
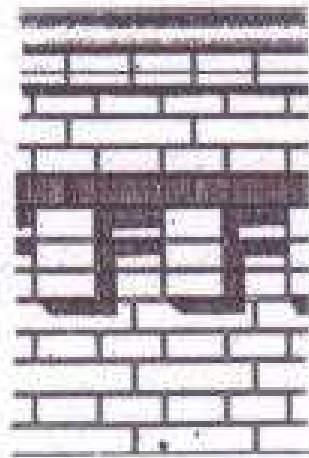
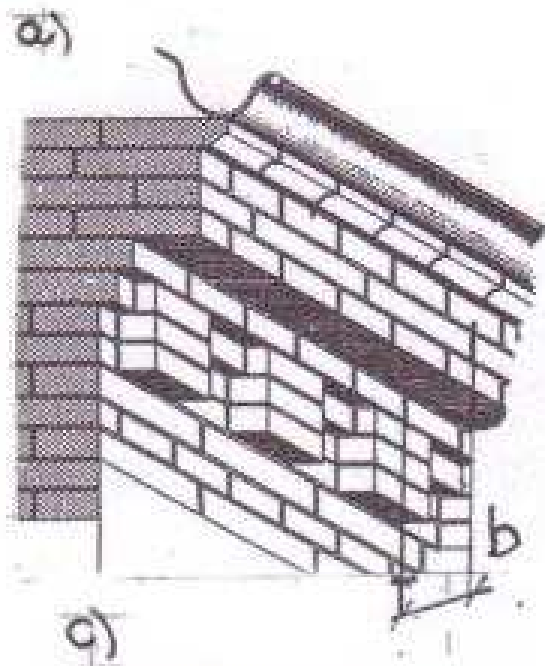



# WP5 Education and Economic Promotion

## Work in progress

- Start of development of workshop concepts, training modules, curricula and training material for general public, house owners and stakeholders, engineers and craftsmen with support of Educational Groups in cooperation with Technical Boards (WP4)
- Execution of workshops for general public, house owners and stakeholders
- Opening of the info-room in Tallinn for showing materials and systems of refurbishment
- Ongoing meetings of Educational Groups
- Articles published in magazines and presentations at other events



Co<sub>2</sub>olBricks



# Summary of partner activities in WP5

WP5 Project partner	Activity	2012, Project period III					2012, Project period IV					2013, Project period V					2013, Project period VI							
		Jan	Feb	Mar	Apr	May	Jun	Jul	Aug	Sep	Oct	Nov	Dec	Jan	Feb	Mar	Apr	May	Jun	Jul	Aug	Sep	Oct	Nov
AZB Hamburg, Germany	ongoing internal meetings of educational groups																							
	Articles for networks focusing on the education aspect																							
	Initial practice exercise on insulation of interior walls																							
	Development of learning modules for craftsmen and pilot training																							
	Integration scheme of new developed materials and promotion																							
Energy Agency for Southeast Sweden																								
Kohila-Jarve Town Government, Estonia	Short term course for householders landlords and public																							
	2 training courses for craftsmen																							
	Seminar for householders, landlords and public																							
The Centre for Development Programs, EMI-ECO, Estonia	General awareness raising workshops for house owners																							
	How to improve energy efficiency in historic buildings (owners)																							
	How to improve energy efficiency in historic buildings (facility managers, craftsmen)																							
	General awareness raising workshops for facility managers and facility maintainers																							
	1-2 articles in „Environmental Engineering“, publishing the results of activities in Estonia																							
	Round table for stakeholders																							
Riga Technical university, Latvia																								
European Foundation for Monuments Protection, Poland																								
Innovation Association Akademechnopark, Belarus	short term course for managers of householder unions																							
	Article in local magazine																							
	presentation in 4th Belarusian Innovation Forum																							
KIINKO - Real Estate Education, Finland	Educational group consisting of representatives of universities, polytechnics etc. as well as vocational training organizations																							
Vilnius Gediminas Technical University, Lithuania	presentation of Co_olBricks project in public fair „Self Education Career 2012“ in Vilnius, Lithuania, establishing the contacts with other teaching institutions from BSR																							
	presentation of Co_olBricks project in public fair „RESTA 2012“ in Vilnius, Lithuania																							
	workshops for administration workers of Lithuanian municipalities and specialists of Lithuanian Built Heritage Preservation departments																							
	workshops for architecture, built heritage conservation and construction students in Vilnius Gediminas Technical University																							
	1-2 articles in representing project activities, articles in local press or international scientific journals																							
Department of Heritage Preservation, Hamburg, Germany	Meetings in Chamber of Architects, Hamburg																							
	Workshop in the “Summer of Architecture” in Hamburg																							

